



ABTRION DECOY

TECHNICAL SPECIFICATIONS

ABTRION DECOY

abtrion.com

The Abtrion Decoy is a cost-effective, rapidly scalable, autonomous one-way drone designed for deployment either individually or in large numbers – with the unique ability to simulate multiple drone types within a single swarm.

Operational Purpose

Engineered to deceive enemy signals intelligence and radar systems, the Abtrion Decoy mimics the signatures of legitimate military platforms. This deception can provoke adversaries to deploy advanced and costly weapon systems – such as surface-to-air missiles – against a low-cost, expendable asset.

By simulating diverse electronic and radar signatures within a coordinated swarm, Abtrion Decoy drones can saturate and overwhelm enemy surveillance and

defense systems, delivering a significant asymmetric advantage. Alternatively, a decoy swarm can be deployed simultaneously with attack drones to further increase mission success rates.

Programmed to fly in patterns and altitudes that replicate military drone operations, each Abtrion Decoy drone appears on radar as a high-value target, using radar-reflective materials and mounted reflectors that mimic the radar cross-section of larger and more complex drones.

To minimize the risk of exposure to enemy electronic warfare (EW) measures, the Abtrion Decoy is designed as a fire-and-forget system, requiring no human intervention after launch. It relies on inertial navigation, allowing it to operate in blackout conditions and GPS-denied environments.

CORE CAPABILITIES

- Autonomous One-Way Mission Profile
- Swarmable Deployment
- Radar Signature Emulation using reflective materials and mounted radar cross-section mimics
- Military Flight Pattern Replication (altitude and route profiles matching real drone missions)
- Fire-and-Forget Operation – no post-launch control required
- Blackout and GPS-Denied Operation – inertial navigation
- Programmable Mission Profiles via pre-launch laptop interface

OPTIONAL CAPABILITIES

- Abtrion Decoy swarm coordination with other attack drones to increase confusion and saturation
- Replayable Radio Transmissions for mimicking legitimate drone communication signals

STRATEGIC IMPACT

By combining these features, Abtrion Decoy drones create a convincing illusion that compels the enemy to engage with high-cost defense systems. This strategy effectively drains adversary resources,

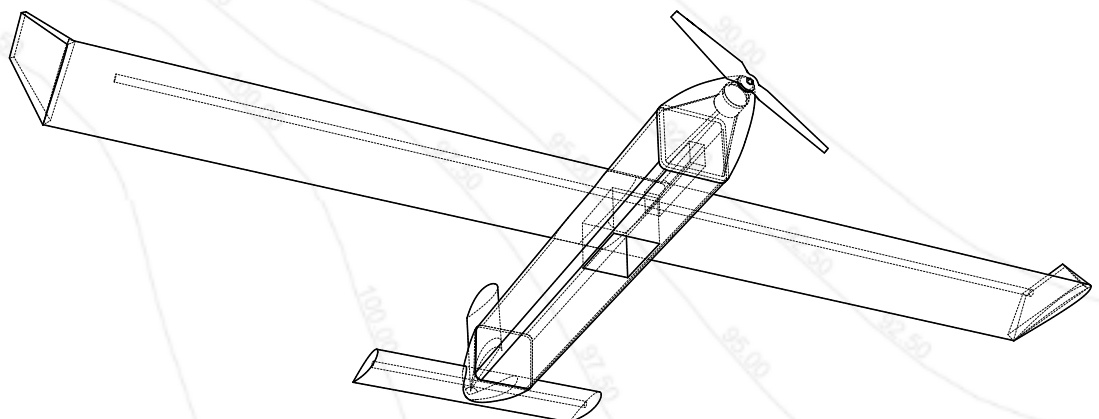

TECHNICAL SPECIFICATIONS

abtrion.com

Flight Performance

- *Range: Up to 200 km*
- *Cruising Speed: 60 km/h (32 knots)*

Physical Characteristics

- *Wingspan: 3.0 meters*
- *Weight: 7 kg*
- *Propulsion: Electric motor*

Deployment & Programming

Launch Methods: Ramp or dolly launch systems for rapid field deployment

Mission Programming Interface: On-site laptop-based setup with input parameter (list of heading, altitude and flight time pairs).

